

Gate Driver Module 2CG010DBC11N

■ Overview

Gate driver 2CG010DBC11N is a dual channel gate driver designed for IGBT.

The high breakdown voltage and low parasitic capacitance make it suitable for gate drives such as IGBT.

■ Features

- Ideal for drive of IGBT
- Gate voltage : +15V/-10V
- ALL-IN-ONE (Built-in isolated DC / DC converter and gate drive circuit)
- Low parasitic capacitance (about 12pF) ; highly resistant to common-mode noise.
- Fast response : about 100nsec(typ)
- The isolation for primary-secondary signal used fast response isolator.
- Input-to-Output dielectric withstand voltage : AC5000V
- Output CH1-to-Output CH2 dielectric withstand voltage : AC4000V
- Input-to-Output insulation distance : 14mm (clearance), 16mm(creepage) (As for Gate driver module PCB)
- Output CH1-to-Output CH2 insulation distance : 7mm (clearance), 12mm(creepage)
- DC/DC converter input voltage : 13~28V
- Signal input voltage : 3.3V,5V
- Overload protection (DC/DC converter)
- Overheat protection (DC/DC converter)
- Half bridge mode (Gate drive circuit)
- Desaturation protection (Gate drive circuit)
- Soft turn-off function (Gate drive circuit)
- Fault signal output function (Gate drive circuit)
- Active clamp function (Gate drive circuit)
- Under-voltage lockout(UVLO) (Gate drive circuit)
- Insulating moistureproof coating
- Safety standards : UL508(file no.E243511) (DC/DC converter only)
- Reinforced isolation according to IEC 60664-1 (IEC61800-5-1, IEC62477-1, IEC62109-1, etc.)
- UL compliant (UL1741, UL508, etc.)

■ Application

Industrial inverter, power conditioner, etc ...

■ Circuit Image

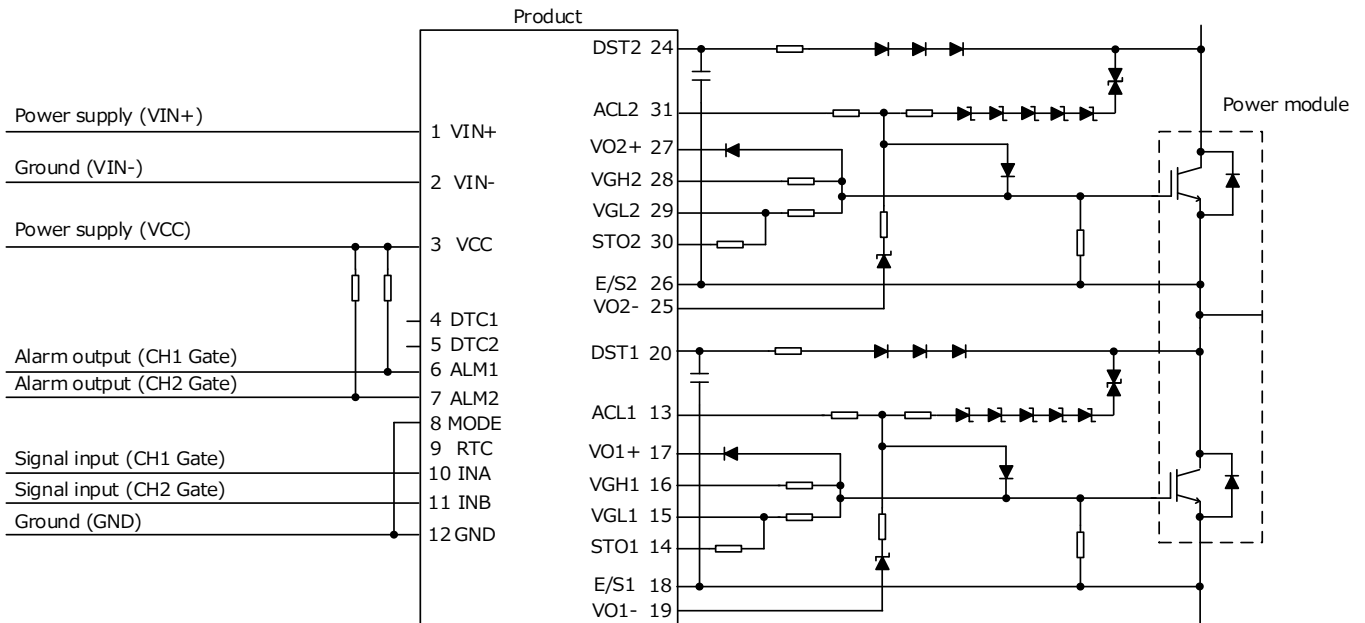

■ Pin Connection

Input

Pin No.	Name	CH	Function
1	VIN+	Common	Power supply for DC/DC converter(+)
2	VIN-	Common	Power supply for DC/DC converter(-)
3	VCC	-	Power supply for drive circuit
4	DTC1	1	Dead time adjustment
5	DTC2	2	Dead time adjustment
6	ALM1	1	Alarm signal output
7	ALM2	2	Alarm signal output
8	MOD	-	Mode select
9	RTC	-	Recovery time of protection circuit control
10	INA	1	Control input A
11	INB	2	Control input B
12	GND	-	Ground for drive circuit

Output

Pin No.	Name	CH	Function
13	ACL1	1	Active clamp pin
14	STO1	1	Soft turn off pin
15	VGL1	1	Gate OFF side pin
16	VGH1	1	Gate ON side pin
17	VO1+	1	DC/DC converter output pin
18	E/S1	1	Emitter · source connection pin
19	VO1-	1	DC/DC converter output pin
20	DST1	1	Desaturation protection pin
21	NONE	-	None
22	NONE	-	None
23	NONE	-	None
24	DST2	2	Desaturation protection pin
25	VO2-	2	DC/DC converter output pin
26	E/S2	2	Emitter · source connection pin
27	VO2+	2	DC/DC converter output pin
28	VGH2	2	Gate ON side pin
29	VGL2	2	Gate OFF side pin
30	STO2	2	Soft turn off pin
31	ACL2	2	Active clamp pin

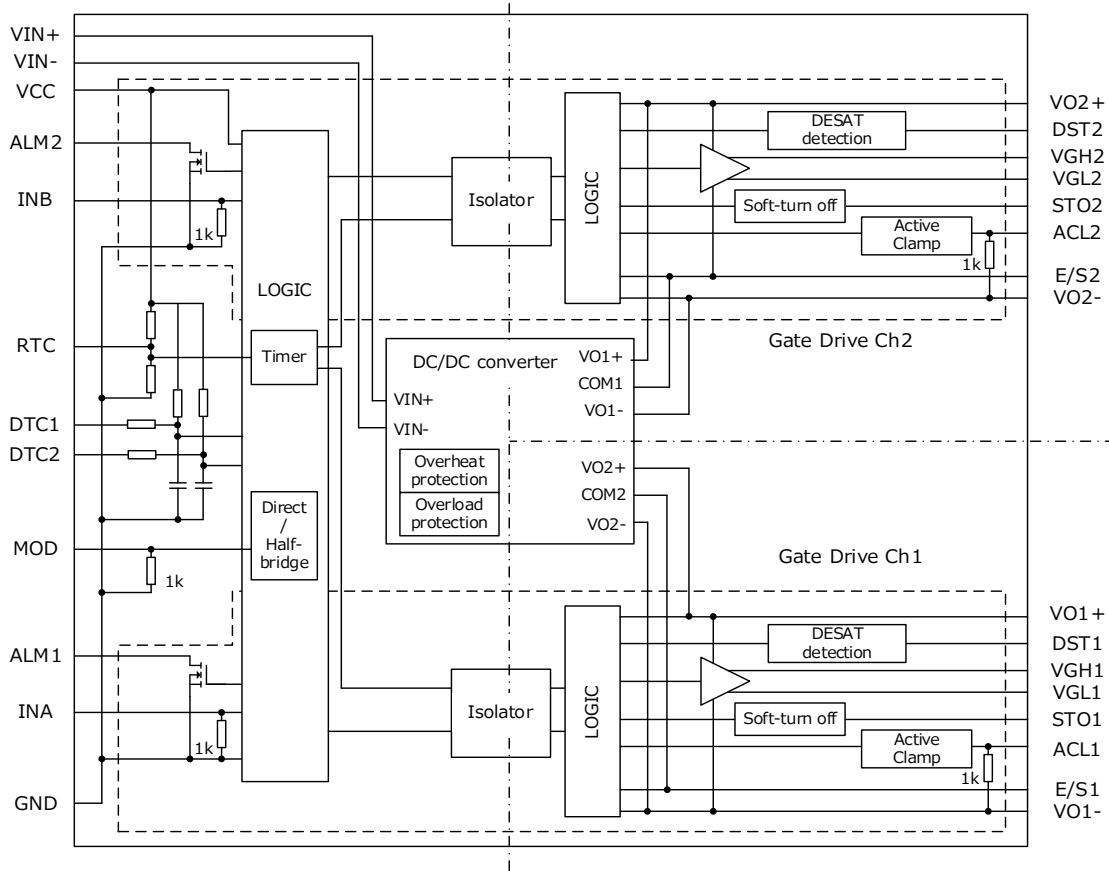
Internal Block Diagram

I/O Condition Table

No.	Status	Input								Output(CH2)				Output(CH1)			
		VO+	DST2	DST1	ACL2	ACL1	MOD	INB	INA	ALM2	VGH2	VGL2	STO2	ALM1	VGH1	VGL1	STO1
1	VO _x + UVLO	UVLO	X	X	X	X	X	X	X	L	Hi-Z	Hi-Z	L	L	Hi-Z	Hi-Z	L
2	ES-VO _x - short	X	X	X	X	X	X	X	X	L	Hi-Z	SD	SD	L	Hi-Z	SD	SD
3	Normal operation (Direct Mode)	○	-	L	-	L	L	-	L	-	-	-	-	Hi-Z	Hi-Z	L	L
4		○	-	L	-	L	L	-	H	-	-	-	-	Hi-Z	H	Hi-Z	Hi-Z
5		○	L	-	L	-	L	L	-	Hi-Z	Hi-Z	L	L	-	-	-	-
6		○	L	-	L	-	L	H	-	Hi-Z	H	Hi-Z	Hi-Z	-	-	-	-
7	Normal operation (Half-bridge Mode)	○	L	L	L	L	H	L	X	Hi-Z	Hi-Z	L	L	Hi-Z	Hi-Z	L	L
8		○	L	L	L	L	H	H	L	Hi-Z	H	Hi-Z	Hi-Z	Hi-Z	Hi-Z	L	L
9		○	L	L	L	L	H	H	H	Hi-Z	Hi-Z	L	L	Hi-Z	H	Hi-Z	Hi-Z
10	Desaturation protection1	○	-	Hi-Z	-	L	L	-	L	-	-	-	-	Hi-Z	Hi-Z	L	L
11		○	-	Hi-Z	-	L	L	-	H	-	-	-	-	L	Hi-Z	Hi-Z	L
12		○	-	Hi-Z	-	L	H	H	H	-	-	-	-	L	Hi-Z	Hi-Z	L
13	Desaturation protection2	○	Hi-Z	-	L	-	L	L	-	Hi-Z	Hi-Z	L	L	-	-	-	-
14		○	Hi-Z	-	L	-	L	H	-	L	Hi-Z	Hi-Z	L	-	-	-	-
15		○	Hi-Z	-	L	-	H	H	H	Hi-Z	Hi-Z	L	L	-	-	-	-
16	Active clamp	○	-	L	-	H	L	-	L	-	-	-	-	Hi-Z	Hi-Z	Hi-Z	L
17		○	L	-	H	-	L	L	-	Hi-Z	Hi-Z	Hi-Z	L	-	-	-	-

○ : VO_x+ UVLO > UVLO, X : Don't care, SD : Shut down

■ Absolute Maximum Ratings

Item	Symbol	Min	Max	Unit	Conditions · Note	
Input voltage for DC/DC converter	V_{IN}	-0.3	28	Vdc	Between VIN+ to VIN-	
Input-side signal voltage	V_{CC}, V_{SG}	-0.3	5.5	V	VCC, RTC, MOD, INA, INB	
	V_{ALM}	-0.3	28	V	ALM1, ALM2	
Input-side signal maximum current	I_{ALM}	-	5	mA	ALM1, ALM2	
DESAT pin input voltage	V_{DESAT}	-0.3	$V_{GH}+0.3$	V		
Active clamp pin input voltage	V_{CLAMP}	$V_{GL}-0.3$	16	V	Between ACLx to VOx- / Duty:2% or less	
Maximum gate current	I_{GPEAK}	-	43	A		
DC/DC converter output power	P_{OUT}	-	4	W	Per output circuit	
Switching frequency	F_{SW}	-	150	kHz	See the permissible frequency curve	
Operating temperature range	$V_{IN}=13.5-18V$	T_{OP}	-40	85	°C	See the permissible frequency curve
	$V_{IN}=18-26.4V$	T_{OP}	-40	75	°C	
Operating humidity	RH_{OP}	20	95	%RH	No condensation	
Storage temperature range	T_{STG}	-40	90	°C		
Storage humidity	RH_{STG}	5	95	%RH	No condensation	

■ Recommended Operating Conditions

Item	Symbol	Min	Max	Unit	Conditions · Note
Input voltage range for DC/DC converter	V_{IN}	13.5	26.4	Vdc	
Input-side signal voltage range	V_{CC}, V_{SG}	3	5.5	Vdc	
Driver circuit number	N	-	2	-	
Logic high level input voltage	V_{SGH}	$V_{CC} \times 0.7$	-	V	MOD, INA, INB
Logic low level input voltage	V_{SGL}	-	$V_{CC} \times 0.3$	V	MOD, INA, INB
Source current of control signal	I_{SG}	5	-	mA	MOD, INA, INB $V_{SG}=5V$
Maximum gate drive capability (150 kHz)	Q_{MAX}	-	160	nC	Gate current (ave) = 24mA Reference value
Maximum gate drive capability (30 kHz)	Q_{MAX}	-	4900	nC	Gate current (ave) = 147mA Reference value
Maximum gate charge amount	Q_G	-	7000	nC	
Minimum input pulse width	t_{INMSK}	60	-	ns	

■ Permissible frequency curve

Total gate charge (Qg) vs permissible frequency curve

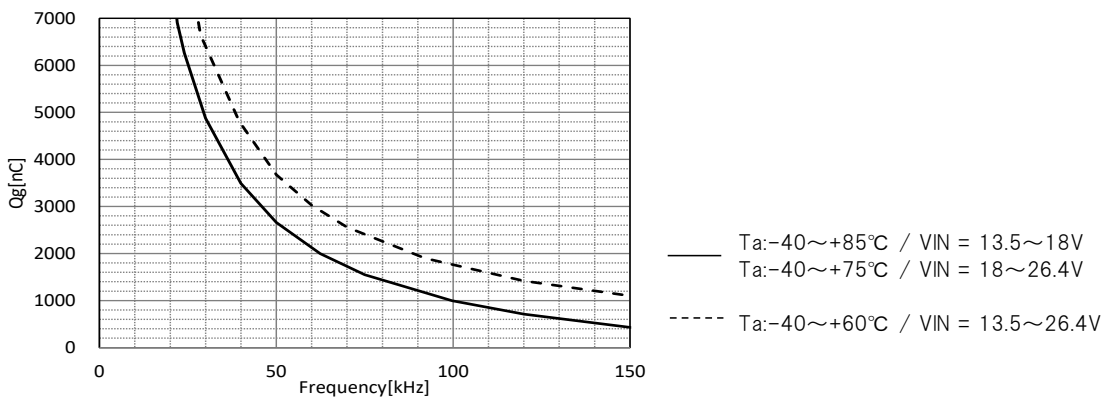

If the active clamp is to be operated repeatedly, subtract 10% from the above curve.

■ Electrical Specification (Vin=24V, Vcc=5V, Ta=25°C, Unless otherwise specified)

Item	Symbol	Min	Typ	Max	Unit	Conditions · Note	
DC/DC converter							
Start-up voltage	V _{START}	-	-	13	V		
Input current	I _{IN}	-	0.42	-	A	Fsw=22kHz / Test load: 280nF	
Standby power	P _{STBY}	-	1.2	-	W	No load	
Logic inputs							
Logic high level input voltage	V _{SGH}	V _{CC} × 0.7	-	-	V	MOD, INA, INB / Guaranteed by design	
Logic low level input voltage	V _{SGL}	-	-	V _{CC} × 0.3	V	MOD, INA, INB / Guaranteed by design	
Logic pull-down resistance	R _{SGD}	-	1000	-	Ω	MOD, INA, INB	
Gate driver output							
Gate ON side pin / output voltage(+)	V _{GH} , V _{O+}	14	15	16	V	No load	
Gate OFF side pin / output voltage(-)	V _{GL} , V _{O-}	-11	-10	-9	V	No load	
Delay time	Turn ON time	t _{PON}	-	100	-	ns	
	Turn OFF time	t _{POFF}	-	100	-	ns	
Dead time	t _{DEAD}	-	4.1	-	us	Half bridge mode	

■ Protection

Item	Symbol	Min	Typ	Max	Unit	Conditions · Note
DC/DC converter						
Overload protection	-	10.5	-	-	W	Auto recovery
Overheat protection	-	120	-	150	°C	Auto recovery, Internal temperature
Gate driver						
Output voltage(H) UVLO OFF voltage	V _{UVLOGHH}	13.2	13.5	13.8	V	Guaranteed by design
Output voltage(H) UVLO ON voltage	V _{UVLOGHL}	12.2	12.5	12.8	V	Guaranteed by design
DESAT charge current	I _{DESAT}	200	240	280	uA	Guaranteed by design
DESAT detection voltage	V _{DESAT}	6.0	6.35	7.0	V	Guaranteed by design
DESAT detection filter time	t _{DSTFIL}	-	400	-	ns	DSTxpin open
DESAT detection time	t _{DSTOUT}	-	450	-	ns	DSTxpin open
Alarm signal output L voltage	V _{ALML}	-	-	0.5	V	I _{ALM} =5mA
Alarm signal output time	t _{ALM}	-	650	-	ns	
Restart time	t _{RESTART}	-	110	-	ms	
Soft turn off duration	t _{SSTO}	-	4	-	us	

■ Insulation

Item	Specification	Conditions · Note
Between Input-Output		
Dielectric withstand voltage	AC5000V	1min, Cutoff 2mA
Insulation resistance	100MΩ or more	DC500V
Partial discharge extinction volt.	1768Vpeak or more	According to EN50178/IEC 60270
Common-mode transient immunity (CMTI)	70kV/us	
Minimum clearance distances	14mm	
Minimum creepage distances	16mm	As for Gate driver module PCB
Between CH1-CH2		
Dielectric withstand voltage	AC4000V	1min, Cutoff 2mA
Insulation resistance	100MΩ or more	DC500V
Partial discharge extinction volt.	1700Vpeak or more	According to EN50178/IEC 60270
Minimum clearance distances	7mm	
Minimum creepage distances	12mm	As for Gate driver module PCB

■ Storage Conditions

Item	Min	Max	Unit	Conditions · Note
Storage temperature	-25	60	°C	A packing state

※If you want to use past the long period there is a concern that the solder non-wetting by terminal oxidation to occur.
Therefore, please use from taking enough tests.

■ Recommended Soldering Condition

- Flow soldering condition : 255±3°C Less than 3sec
Temperature of preheating 110°C~130°C
End temperature of preheating 110°C±10°C
- Soldering condition of hand work : 360°C(MAX) Less than 3sec

■ Usage Cautions

- Always mount fuse on the plus side of input for ensuring safety because the fuse is not built-in the product.
Please select the fuse considering conditions such as steady current, inrush current, and ambient temperature.
When using a fuse having large rated current or high capacity input electrolytic condenser, by combining another converter and input line and input electrolytic condenser, fuse may not blow off in the case of abnormality.
Do not combine high voltage line and fuse.
- Make sure the rise/fall time of the input signal is 500ns or less.
- This product has DESAT protection for arm short circuit and load short circuit protection.
However, even if this protection works, the IGBT may be damaged if abnormally high current occurs due to IGBT's characteristics variations or the load short-circuit mode during parallel operation.
To ensure safety, be sure to check the short-circuit current at the unit in which this product is integrated, and evaluate whether it can protect under the condition that there is no damage to the IGBT.
- The coating material is applied to the product, so it may appear to be partially whitened.
This does not affect the characteristics of the product.

■ Outline Dimensional Drawing

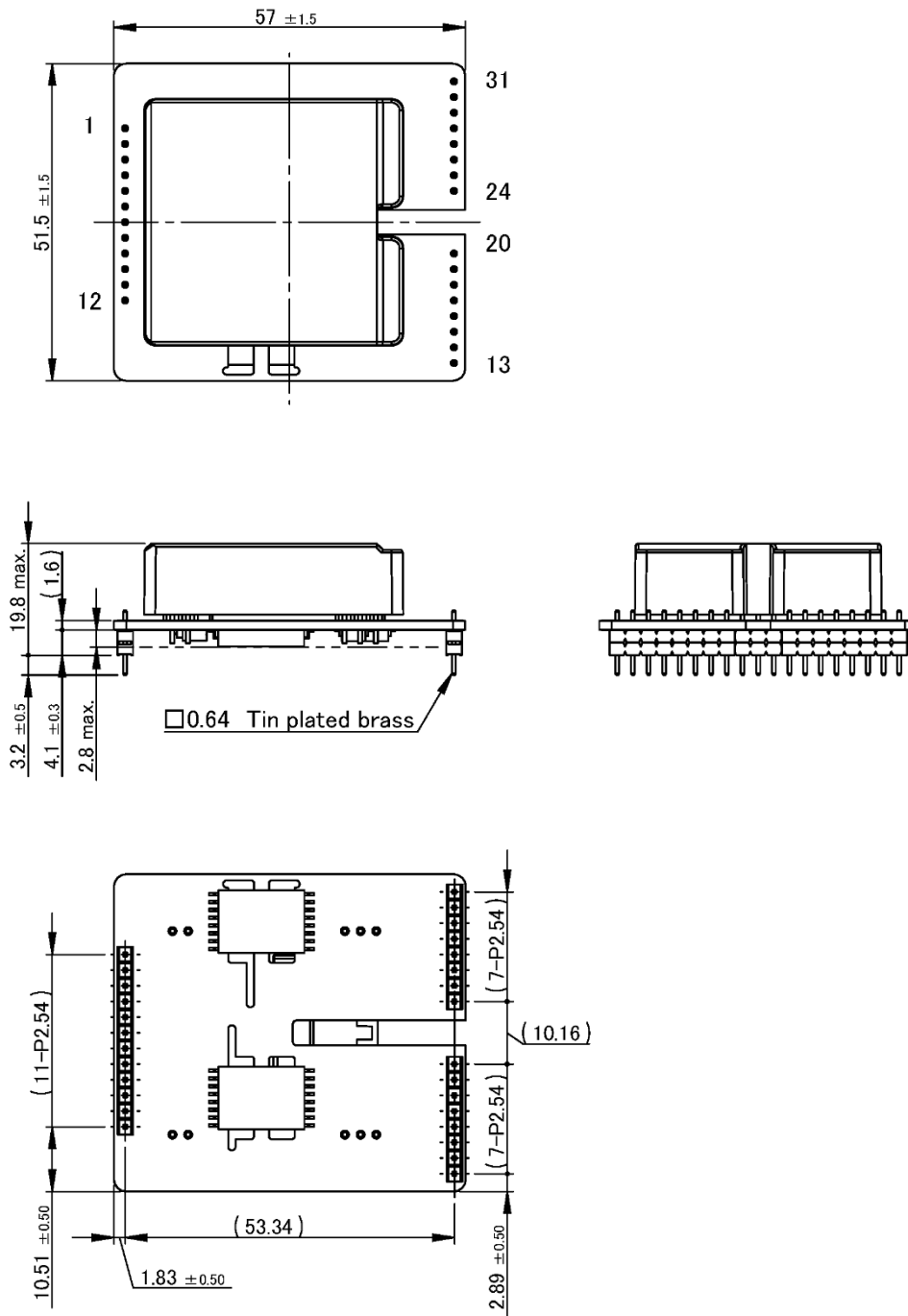

Unit: mm

Note: 1. The dimensional tolerance without directions is $\pm 0.5\text{mm}$.

■ Product Weight

45.0g(typ)

■ Important Notice

- This information and product are subject to change without prior notice for the purpose of improvements, etc.
Ensure that you are in possession of the most up-to-date information when using this product.
- The operation examples and circuit examples shown in this document are for reference purposes only, and TAMURA Corporation disclaims all responsibility for any violations of industrial property rights, intellectual property rights and any other rights owned by TAMURA Corporation or third parties that these may entail.
- The circuit examples and part constants listed in this document are provided as reference for the verification of characteristics. You are to perform design, verification, and judgment at your own responsibility, taking into account the various conditions.
- TAMURA has evaluated the efficiency and performance of this product in a usage environment determined by us.
Depending on your usage environment or usage method, there is the possibility that this product will not perform sufficiently as shown in the specifications, or may malfunction.
When applying this product to your devices or systems, please ensure that you conduct evaluations of their state when integrated with this product. You are responsible for judging its applicability.
TAMURA bears no responsibility whatsoever for any problems with your devices, systems or this product which are caused by your usage environment or usage method.
- TAMURA Corporation constantly strives to improve quality and reliability, but malfunction or failures are bound to occur with some probability in power products. To ensure that failures do not cause accidents resulting in injury or death, fire accidents, social damage, and so on, you are to thoroughly verify the safety of their designs in devices and/or systems, at your own responsibility.
- This product is intended for use in consumer electronics (electric home appliances, business equipment, Information equipment, communication terminal equipment, measuring devices, and so on.) If considering use of this product in equipment or devices that require high reliability (medical devices, transportation equipment, traffic signal control equipment, fire and crime prevention equipment, aeronautics and space devices, nuclear power control, fuel control, in-vehicle equipment, safety devices, and so on), please consult a TAMURA sales representative in advance. Do not use this product for such applications without written permission from TAMURA Corporation.
- This product is intended for use in environments where consumer electronics are commonly used.
It is not designed for use in special environments such as listed below, and if such use is considered, you are to perform thorough safety and reliability checks at your own responsibility.
 - Use in liquids such as water, oil, chemical solutions, or organic solvents, and use in locations where the product will be exposed to such liquids.
 - Use that involves exposure to direct sunlight, outdoor exposure, or dusty conditions.
 - Use in locations where corrosive gases such as salt air, C12, H2S, NH3, SO2, or NO2, are present.
 - Use in environments with strong static electricity or electromagnetic radiation.
 - Use that involves placing inflammable material next to the product.
 - Use of this product either sealed with a resin filling or coated with resin.
 - Use of water or a water soluble detergent for flux cleaning.
 - Use in locations where condensation is liable to occur.
- This product is not designed to resist radiation.
- This product is not designed to be connected in series or parallel.
Do not operate this product in a series, parallel, or N+1 redundant configuration.
- Do not use or otherwise make available the TAMURA products or the technology described in this document for any military purposes, including without limitation, for the design, development, use, stockpiling or manufacturing of mass destruction weapons (e.g. nuclear, chemical, or biological weapons or missile technology products).
When exporting and re-exporting the products or technology described in this document, you should comply with the applicable export control laws and regulations and follow the procedures required by such laws and regulations including, without limitation, Japan -Foreign Exchange and Foreign Trade Control Law and U.S.- Export Administration Regulations.
The TAMURA products and related technology should not be used for or incorporated into any products or systems whose manufacture, use, or sale is prohibited under any applicable domestic or foreign laws or regulations.
- Please contact your TAMURA sales office for details as to environmental matters such as the RoHS compatibility of product.
Please use TAMURA products in compliance with all applicable laws and regulations that regulate the inclusion or use of controlled substances, including without limitation, the EU RoHS Directive.
TAMURA assumes no liability for damages or losses occurring as a result of your noncompliance with applicable laws and regulations.
- TAMURA assumes no liability for damages or losses incurred by you or third parties as a result of unauthorized use of TAMURA products.
- This document and any information herein may not be reproduced in whole or in part without prior written permission from TAMURA.