

テレコム用トランス  
Telecommunication Transformers

12T SERIES

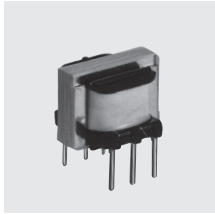

- 小型軽量
  - 自動挿入機対応
  - 最大入力レベル 0 dBm
  - 周波数帯域 300Hz ~ 10KHz
  - 耐電圧 AC500Vr.m.s. 1 分間
  - 絶縁抵抗 DC500V 100MΩ以上
  - 最低発注量 100 個
- Compact and light weight type
  - Availability of automatic insertion machine
  - MAX. level: 0 dBm
  - Frequency range: 300Hz~10KHz
  - Dielectric strength: AC500Vr.m.s. 1 minute.
  - Insulation resistance: DC500V 100MΩ MIN.
  - Minimum ordering quantity: 100pcs

寸法図 DIMENSIONS (mm)

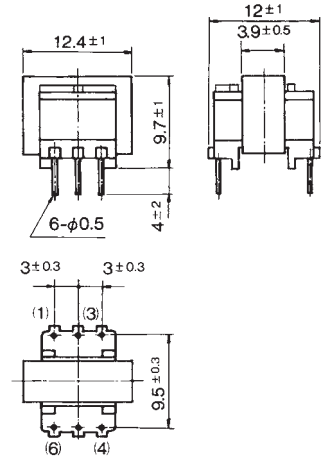

参考質量 Reference Weight 3.3g

ストック マーク Stock mark	カタログ品番 Catalog No.	インピーダンス(Ω) Impedance		Pri. DC (mA)	定損 Loss @1 KHz (dB)	周波数特性 Frequency Response (dB)	巻線比 Turns Ratio	D.C.R.(Ω) 約 approx.		結線図 Schematic	備考 Note
		Pri.	Sec.					Pri.	Sec.		
●	12T01	600	600	0	1.7	±0.7	1:1.00	48	61	1	
●	12T02	600	300	0	1.7	±0.7	1:0.707	48	33	1	
●	12T03	600	150	0	1.7	±0.7	1:0.500	48	15	1	
●	12T04	300	300	0	2.0	±0.5	1:1.00	29	36	1	

14T SERIES

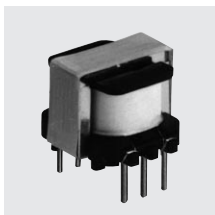

- 小型軽量
  - 自動挿入機対応
  - 断線防止構造
  - 自動生産ライン対応
  - 最大入力レベル +5 dBm
  - 周波数帯域 300Hz ~ 10KHz
  - 耐電圧 AC500Vr.m.s. 1 分間
  - 絶縁抵抗 DC500V 100MΩ以上
  - 最低発注量 50 個
- Compact and light weight type
  - Availability of automatic insertion machine
  - Availability of automatic production line
  - MAX. level: +5 dBm
  - Frequency range: 300Hz~10KHz
  - Dielectric strength: AC500Vr.m.s. 1 minute.
  - Insulation resistance: DC500V 100MΩ MIN.
  - Minimum ordering quantity: 50pcs

寸法図 DIMENSIONS (mm)

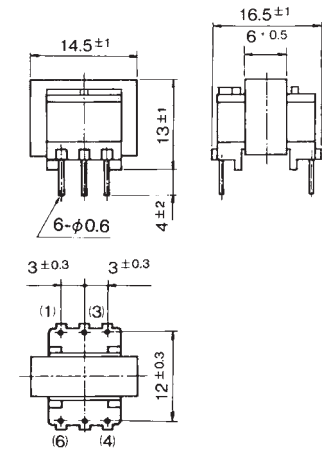

参考質量 Reference Weight 6.0g

ストック マーク Stock mark	カタログ品番 Catalog No.	インピーダンス(Ω) Impedance		Pri. DC (mA)	定損 Loss @1 KHz (dB)	周波数特性 Frequency Response (dB)	巻線比 Turns Ratio	D.C.R.(Ω) 約 approx.		結線図 Schematic	備考 Note
		Pri.	Sec.					Pri.	Sec.		
●	14T03	600CT	600CT	0	2.0	±1.0	1:1.00	64	78	3	
●	14T04	600	600	0	2.0	±1.0	1:1.00	64	78	1	
●	14T06	600	8	0	2.0	±1.0	1:0.115	64	0.59	1	
●	14T07	600	600CT	0	1.2	±0.3	1:1.00	35	45	2	
●	14T08	10K	10K	0	1.7	±1.0	1:1.00	330	420	1	

12T, 14T SERIES / 結線図 SCHEMATIC



# テレコム用トランス Telecommunication Transformers

## 19T SERIES

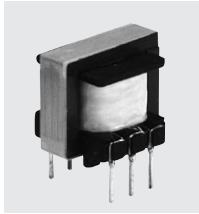

- 自動挿入機対応
  - 断線防止構造
  - 自動生産ライン対応
  - 最大入力レベル +10 dBm
  - 周波数帯域 300Hz ~ 4.0KHz
  - 耐電圧 AC500Vr.m.s. 1分間
  - 絶縁抵抗 DC500V 100MΩ以上
  - 最低発注量 20個
- Availability of automatic insertion machine
  - Availability of automatic production line
  - MAX. level: +10 dBm
  - Frequency range: 300Hz~4.0KHz
  - Dielectric strength: AC500Vr.m.s. 1 minute
  - Insulation resistance: DC500V 100MΩ MIN.
  - Minimum ordering quantity: 20pcs

### 寸法図 DIMENSIONS (mm)

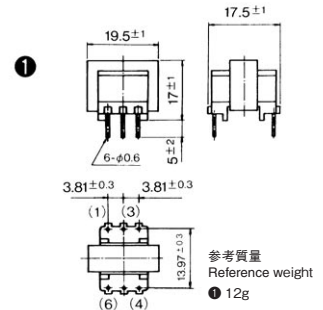

ストックマーク Stock mark	カタログ品番 Catalog No.	インピーダンス(Ω) Impedance		Pri DC (mA)	定損 Loss @1KHz (dB)	周波数特性(dB) Frequency Response	巻線比 Turns Ratio	D.C.R.(Ω) 約 approx.		結線図 Schematic	寸法図 Dimension	備考 Note
		Pri.	Sec.					Pri.	Sec.			
●	19T03	600CT	600CT	0	1.5	±0.6	1:1.00	33	42	3	1	
●	19T04	600	600	0	1.5	±0.6	1:1.00	33	42	1	1	
●	19T07	600	600	80	2.5	±1.0	1:1.00	68	170	1	2	600Hz~3.5KHz
●	19T17	600/150	600	50	1.5	±1.8	1:1.00	62	78	16	4	

### 19T SERIES / 結線図 SCHEMATIC

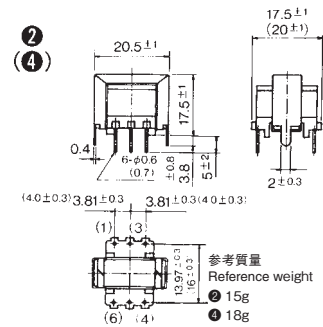
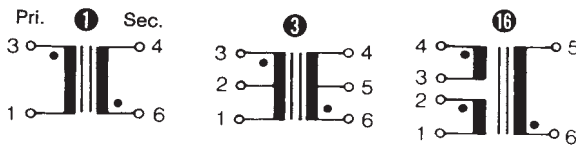

## 19Y SERIES

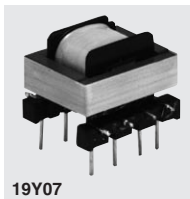

- 薄型構造
  - 自動挿入機対応
  - 断線防止構造
  - 自動生産ライン対応
  - 最大入力レベル +10 dBm
  - 周波数帯域 300Hz ~ 4.0KHz
  - 耐電圧 AC500Vr.m.s. 1分間
  - 絶縁抵抗 DC500V 100MΩ以上
  - 最低発注量 30個
- Low-profile construction
  - Availability of automatic insertion machine
  - Availability of automatic production line
  - MAX. level: +10 dBm
  - Frequency range: 300Hz~4.0KHz
  - Dielectric strength: AC500Vr.m.s. 1 minute.
  - Insulation resistance: DC500V 100MΩ MIN.
  - Minimum ordering quantity: 30pcs

ストックマーク Stock mark	カタログ品番 Catalog No.	インピーダンス(Ω) Impedance		Pri DC (mA)	定損 Loss @1KHz (dB)	周波数特性 Frequency Response (dB)	巻線比 Turns Ratio	D.C.R.(Ω) 約 approx.		結線図 Schematic	寸法図 Dimension	備考 Note
		Pri.	Sec.					Pri.	Sec.			
●	19Y07	600	600CT, 600CT	0	1.5	±2.0	1:1.00	33	74	20	1	Hybrid
●	19Y11	600	600	80	2.0	±1.7	1:1.04	76	98	1	2	
●	19Y13	600	600	80	1.7	±1.5	1:1.04	76	98	1	2	

### 19Y SERIES / 結線図 SCHEMATIC

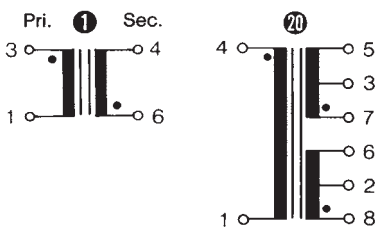

### 寸法図 DIMENSIONS (mm)

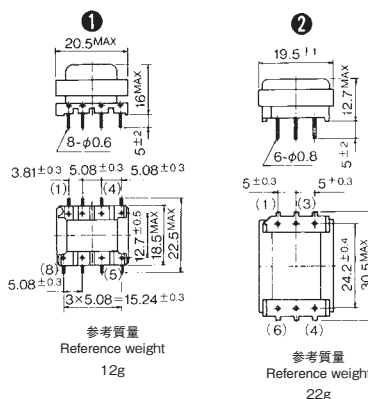

# テレコム用トランス Telecommunication Transformers

## 30Y SERIES



- 薄型構造
  - 断線防止構造
  - 自動生産ライン対応
  - 最大入力レベル +15 dBm
  - 周波数帯域 300Hz ~ 4.0KHz
  - 耐電圧 AC500Vr.m.s. 1分間
  - 絶縁抵抗 DC500V 1000MΩ以上
  - 最低発注量 20個
- Low-profile construction
  - Availability for automatic production line
  - MAX. level: +15 dBm
  - Frequency range: 300Hz~4.0KHz
  - Dielectric strength: AC500Vr.m.s. 1 minute.
  - Insulation resistance: DC500V 1000MΩ MIN.
  - Minimum ordering quantity: 20pcs

ストックマーク Stock mark	カタログ品番 Catalog No.	インピーダンス(Ω) Impedance		Pri DC (mA)	定損 Loss @1KHz (dB)	周波数特性(dB) Frequency Response	巻線比 Turns Ratio	D.C.R.(Ω) 約 approx.		結線図 Schematic
		Pri.	Sec.					Pri.	Sec.	
●	30Y01	600/150	600	120	1.2	±2.0	1:1.00	58	47	7

寸法図 DIMENSIONS (mm)

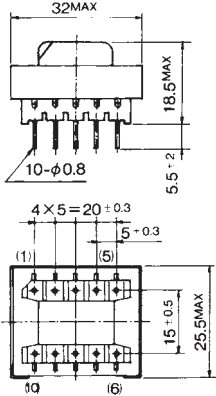

参考質量 Reference Weight 48g

### 30Y SERIES / 結線図 SCHEMATIC

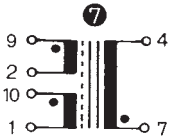

## 16L SERIES

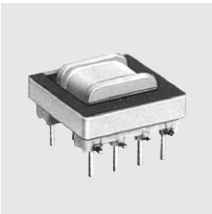

- 薄型構造
  - 断線防止構造
  - 平板ピン
  - 最大入力レベル +5 dBm (01 ~ 02) +10 dBm (06 ~ 07)
  - 周波数帯域 300Hz ~ 10KHz
  - 耐電圧 AC1000Vr.m.s. 1分間 (1次-2次、鉄心間)
  - 絶縁抵抗 DC500V 100MΩ以上
  - 最低発注量 20個
- Low-profile construction
  - Flat pin terminal
  - MAX. level: +5 dBm (01~02), +10 dBm (06~07)
  - Frequency range: 300Hz~10KHz
  - Dielectric strength: AC1000Vr.m.s. 1 minute (Pri.-Sec. and Core)
  - Insulation resistance: DC500V 100MΩ MIN.
  - Minimum ordering quantity: 20pcs

ストックマーク Stock mark	カタログ品番 Catalog No.	インピーダンス(Ω) Impedance		Pri DC (mA)	定損 Loss @1KHz (dB)	周波数特性(dB) Frequency Response	巻線比 Turns Ratio	D.C.R.(Ω) 約 approx.		結線図 Schematic	備考 Note
		Pri.	Sec.					Pri.	Sec.		
●	16L01	600	1200/300	0	1.1	±0.4	1:1.41	27	78	23	Hybrid
●	16L02	600	600	0	1.1	±0.4	1:1.00	27	33	22	
●	16L06	600	600	0	1.5	±0.7	1:1.00	27	33	22	
●	16L07	600/150	600/150	0	1.5	±0.7	1:1.00	27	33	24	

寸法図 DIMENSIONS (mm)

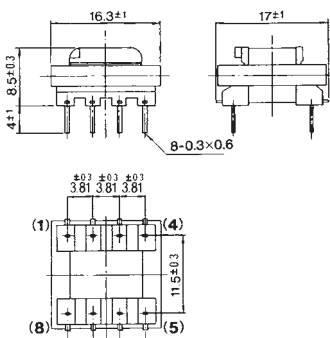

参考質量 Reference Weight 6.7g

### 16L SERIES / 結線図 SCHEMATIC

