

磁気平衡式 / 電圧出力型 耐外部磁界ノイズ強化タイプ
 Servo system / Voltage-output type External magnetic field improvement type

S22P M2 SERIES



仕様 SPECIFICATIONS

Ta=25°C, RL=10kΩ, Vcc=+5V

カタログ品番 Types		S22P006S05M2	S22P015S05M2	S22P025S05M2
項目 Spec				
定格電流 Primary nominal current	If	6A	15A	25A
飽和電流 Saturation current	Ifmax	±18A	±45A	±75A
定格出力電圧 Rated output voltage	Vo	Vof±0.625V (at If)		
定格出力電圧精度 Output voltage accuracy	XG	0.625V±10mV (at If)		
オフセット電圧 Offset voltage	Vof	2.5V±50mV	2.5V±20mV	2.5V±15mV
出力直線性 Output linearity	εL	≤±0.2%(at If)		
電源電圧 Power supply voltage	Vcc	+5V±5%		
消費電流 Consumption current	ICC	Typ. 12.5mA (If=0) + 37.5mA (Ifmax)		
di/dt 応答速度 Response time	Tr	≤1μs (at di/dt = If/μs)		
出力電圧温度特性 Thermal drift of gain	TcVo	±0.05mV / °C		
オフセット電圧温度特性 Thermal drift of offset	TcVof	-10~25°C:±1.6mV / °C 25~85°C:±0.8mV / °C	-10~25°C:±0.6mV / °C 25~85°C:±0.3mV / °C	-10~25°C:±0.4mV / °C 25~85°C:±0.2mV / °C
ヒステリシス誤差 Hysteresis error	VoH	≤0.5mV (at If = 0A → If → 0A)		
絶縁耐圧 Insulation voltage	Vd	AC3000V, 1分間(感応電流0.5mA) 1次 ⇔ 2次間 AC3000V for 1 minute (Sensing current 0.5mA) Primary ⇔ Secondary		
絶縁抵抗 Insulation resistance	Ris	≥500MΩ (at DC500V) 1次 ⇔ 2次間 ≥500MΩ (at DC500V) Primary ⇔ Secondary		
動作温度範囲 Ambient Operating temperature	TA	-10°C~+85°C		
保存温度範囲 Ambient storage temperature	TS	-25°C~+100°C		

外形図 DIMENSIONS (mm)

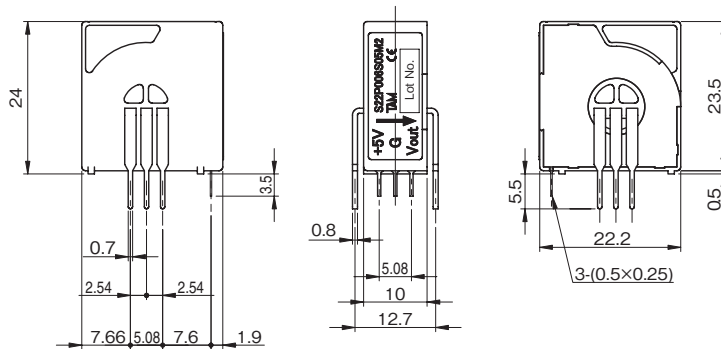

質量 Weight:
8g typ

注 Note
 1. 指示なき寸法公差は±0.5mm
 Unless otherwise specified,
 tolerances shall be ±0.5mm
 2. 外形寸法の単位はmmとする。
 Unit is [mm]

